

PRESTIGE 2

REFRIGERATED | MEAT | FISH | CHEESE | PREPARED FOODS



Project: _____ Item #: _____

Location: _____ Approved: _____

631-981-2100

Display Case

Standard Features:

- Large display area
- LED lighting
- Double pane glass
- Straight glass (VD) or Curved Glass (VC) available
- Temperature control panel
- White exterior, RAL 9003
- Stainless steel worktop
- Front glass opens for easy cleaning access
- Easily removable front access cover



Optional Accessories:

- Castor Kit (add 3" to height)
- Channel Kit (to seam two separate cases together without side panels)
- Paint exterior panels, customer choice of RAL color
- 90° corner case, (must be channeled to another case only available in straight glass)

PRESTIGE 2



REFRIGERATED | MEAT | FISH | CHEESE | PREPARED FOODS

Refrigerated With Under Storage (RT)

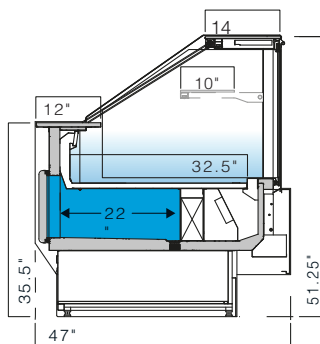

Refrigerated Without Under Storage (RS)

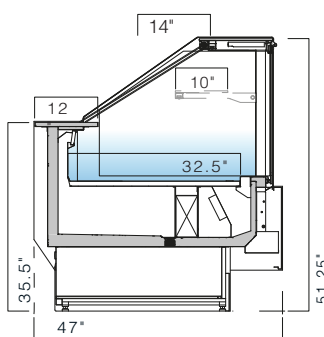

Technical Specifications & Electrical Requirements

Style	Model #	Dimensions W x D x H (In.)	Amps.	HP	Nema Plug
With Under Storage (RT)	P2RT - 937	38.5"x 47"x 51.25	7	1/2	6-15P
	P2RT - 1250	51"x 47"x 51.25	8	1/2	6-15P
	P2RT - 1562	63.25"x 47"x 51.25	10	1	6-15P
	P2RT - 1875	75.5"x 47"x 51.25	10	1 1/4	6-15P
	P2RT - 2500	100"x 47"x 51.25	10	1 1/4	6-15P
	P2RT - 3125	125"x 47"x 51.25	10	1 1/4	6-15P
	P2RT - 3750	149.5"x 47"x 51.25	10	1 1/4	6-15P
Without Under Storage (RS)	P2RS - 937	38.5"x 47"x 51.25	7	1/2	6-15P
	P2RS - 1250	51"x 47"x 51.25	8	1/2	6-15P
	P2RS - 1562	63.25"x 47"x 51.25	10	1	6-15P
	P2RS - 1875	75.5"x 47"x 51.25	10	1 1/4	6-15P
	P2RS - 2500	100"x 47"x 51.25	10	1 1/4	6-15P
	P2RS - 3125	125"x 47"x 51.25	10	1 1/4	6-15P
	P2RS - 3750	149.5"x 47"x 51.25	10	1 1/4	6-15P

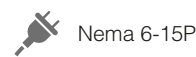
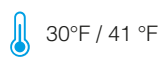
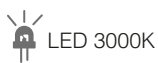

Important Notes: Performance issues (product temperatures, water on floor, etc.) caused by adverse conditions are not covered by warranty. Keep unit at least 15" from exterior doors, overhead HVAC vents, or any air curtain disruption. Do not expose unit to direct sunlight or any heat source (ovens, fryers, etc.). Tile floors, low ceilings, or small rooms will increase noise level. Compressor air lower front intake. Front panel cannot be blocked.

All technical data, pictures and drawings contained in this document are not binding on the manufacturer, nor can the manufacturer be held liable for any modification of the machine, in part or in whole.

PRESTIGE 2

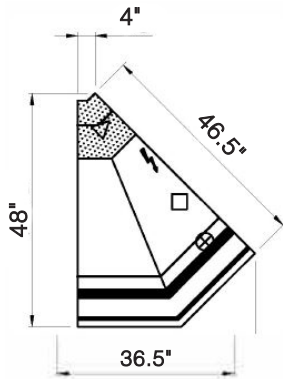

CEF 45°

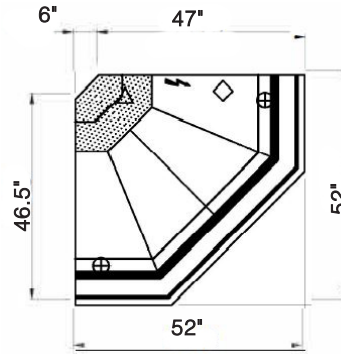

CEF 90°

(Only Available Remote)

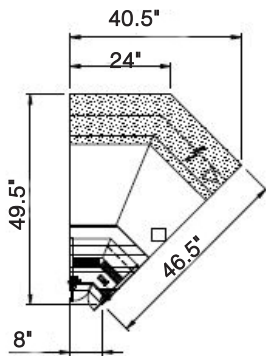

CIF 45°

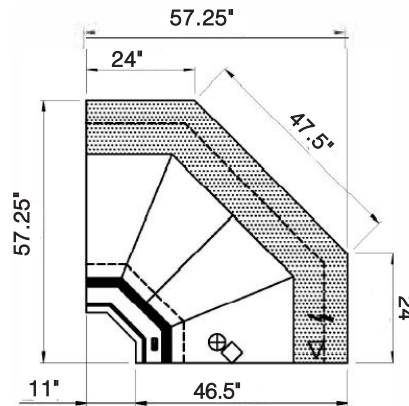

CIF 90°

Technical Specifications & Electrical Requirements

Glass Style	Model #	Dimensions W x D x H (In.)	Amps.	HP	Nema Plug
90° Corner	P2-CEF 90	53.25"x46.5"x51.25"	10	5/8	6-15P
	P2-CIF 90	97.5"x57.25"x51.25"	10	5/8	6-15P
45° Corner	P2-CEF 45	38.5"x48.5"x51.25"	10	5/8	6-15P
	P2-CIF 45	42.5"x49.5"x51.25"	10	5/8	6-15P

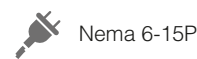
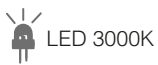

Important Notes: Performance issues (product temperatures, water on floor, etc.) caused by adverse conditions are not covered by warranty. Keep unit at least 15' from exterior doors, overhead HVAC vents, or any air curtain disruption. Do not expose unit to direct sunlight or any heat source (ovens, fryers, etc.). Tile floors, low ceilings, or small rooms will increase noise level. Compressor air lower front intake. Front panel cannot be blocked.

All technical data, pictures and drawings contained in this document are not binding on the manufacturer, nor can the manufacturer be held liable for any modification of the machine, in part or in whole.