

new

# PRESTIGE 2

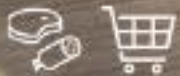

gti **DESIGNS**



## PRESTIGE 2

### MAXIMUM VISIBILITY

Large display area providing perfect visibility of the products.



## PRESTIGE 2

### MAXIMUM VISIBILITY

A large display area that offers perfect visibility, excellent product promotion



**LED lighting that brings out the natural colours of the products**

- ✓ Optimised lamp location and angle
- ✓ The correct colour for every product
- ✓ Low energy consumption
- ✓ 4000 K colour | 4000 K meat – *NEW*

## PRESTIGE 2

### MAXIMUM VISIBILITY

A large display area that offers perfect visibility, excellent product promotion



*Curved front glass: on request and on quotation*

- ✓ **2 styles, 2 front glass options:** flat (VPV) and curved (VC) with LED illumination on the upper glass shelf





## PRESTIGE 2

### MAXIMUM VISIBILITY

A large display area that offers perfect visibility, excellent product promotion



- ✓ **2 styles, 2 front glass options:** flat (VPV) and curved (VC) with LED illumination on the upper glass shelf
- ✓ **Intermediate glass shelf with LED lighting** to cross-sell non-refrigerated products

## PRESTIGE 2

### MAXIMUM VISIBILITY

A large display area that offers perfect visibility, excellent product promotion



- ✓ **2 styles, 2 front glass options:** flat (VPV) and curved (VC) with LED illumination on the upper glass shelf
- ✓ **Intermediate glass shelf with LED lighting** to cross-sell non-refrigerated products
- ✓ **Front glass with anti-condensation system**
- ✓ **Large double-glazed side**



PRESTIGE 2

## HIGH PERFORMANCE & TECHNOLOGY

- ✓ Smooth, balanced ventilated cooling for a **uniform temperature** throughout the display area
- ✓ **Temperature class M1** (-1... +5 °C) display cases e corners
- ✓ **Refrigerant fluid R290**
- ✓ **Fans with adjustable speed** through potentiometer
- ✓ **Solar thermometer**  
no batteries, no maintenance, no cost





## HIGH PERFORMANCE & TECHNOLOGY

- ✓ Front glass with ventilated anti-condensation system with very low power consumption
- ✓ Double-glazed end side panels
- ✓ Service area with sliding acrylic doors  
Curtain option, not available for corners.



PRESTIGE 2

## CARE & HYGIENE

Quick and uncomplicated!

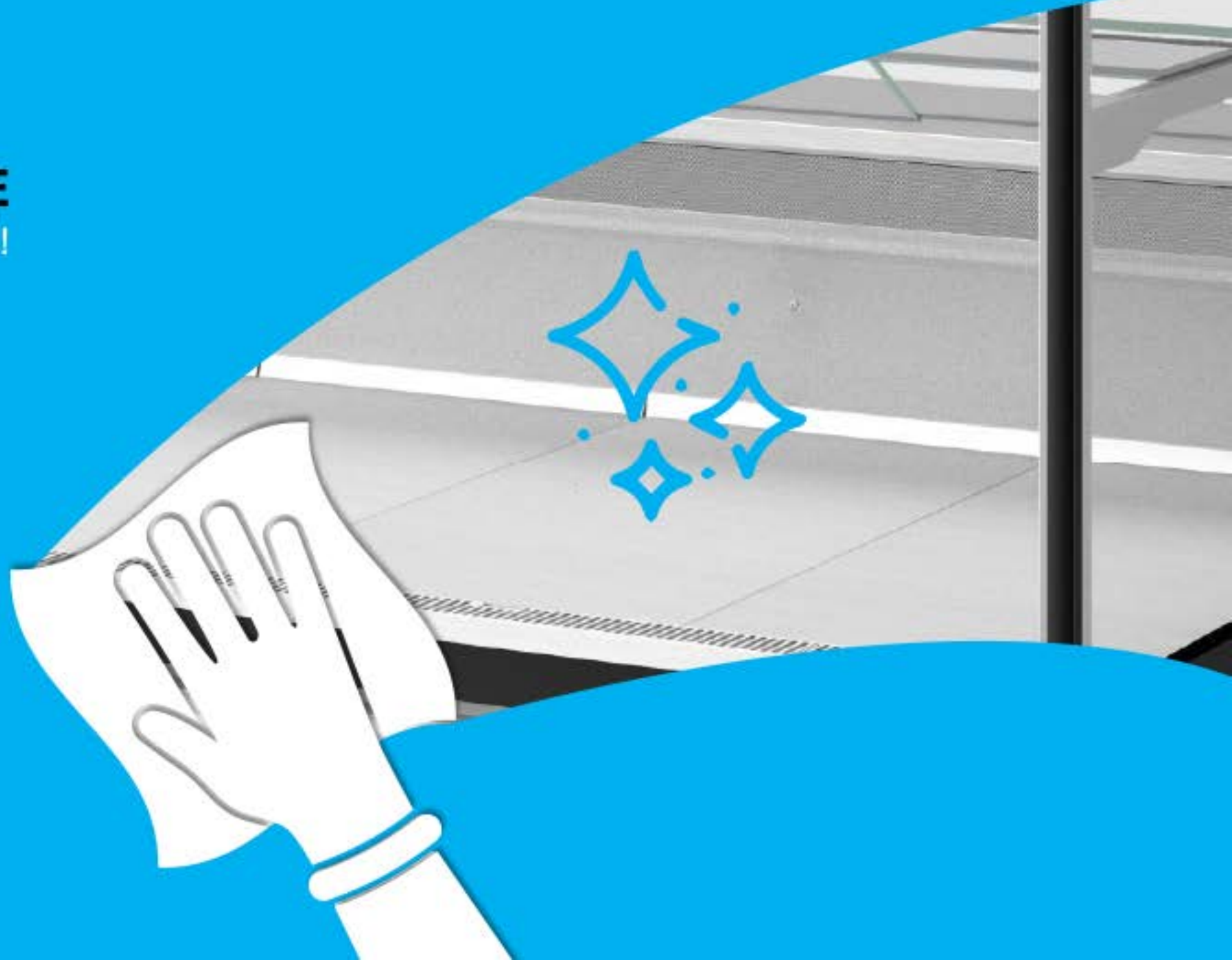

## PRESTIGE 2

### CARE & HYGIENE

Quick and uncomplicated!

- ✓ **Stainless steel interior and exterior vat**
- ✓ **Stainless steel worktop**
- ✓ **Wide front glass opening**  
for easy front access, display case and corners.
- ✓ **Easy to remove display trays,**  
for effective cleaning of the vat.
- ✓ **Easy to remove condenser access cover,**  
magnetic, no screws, no tools.

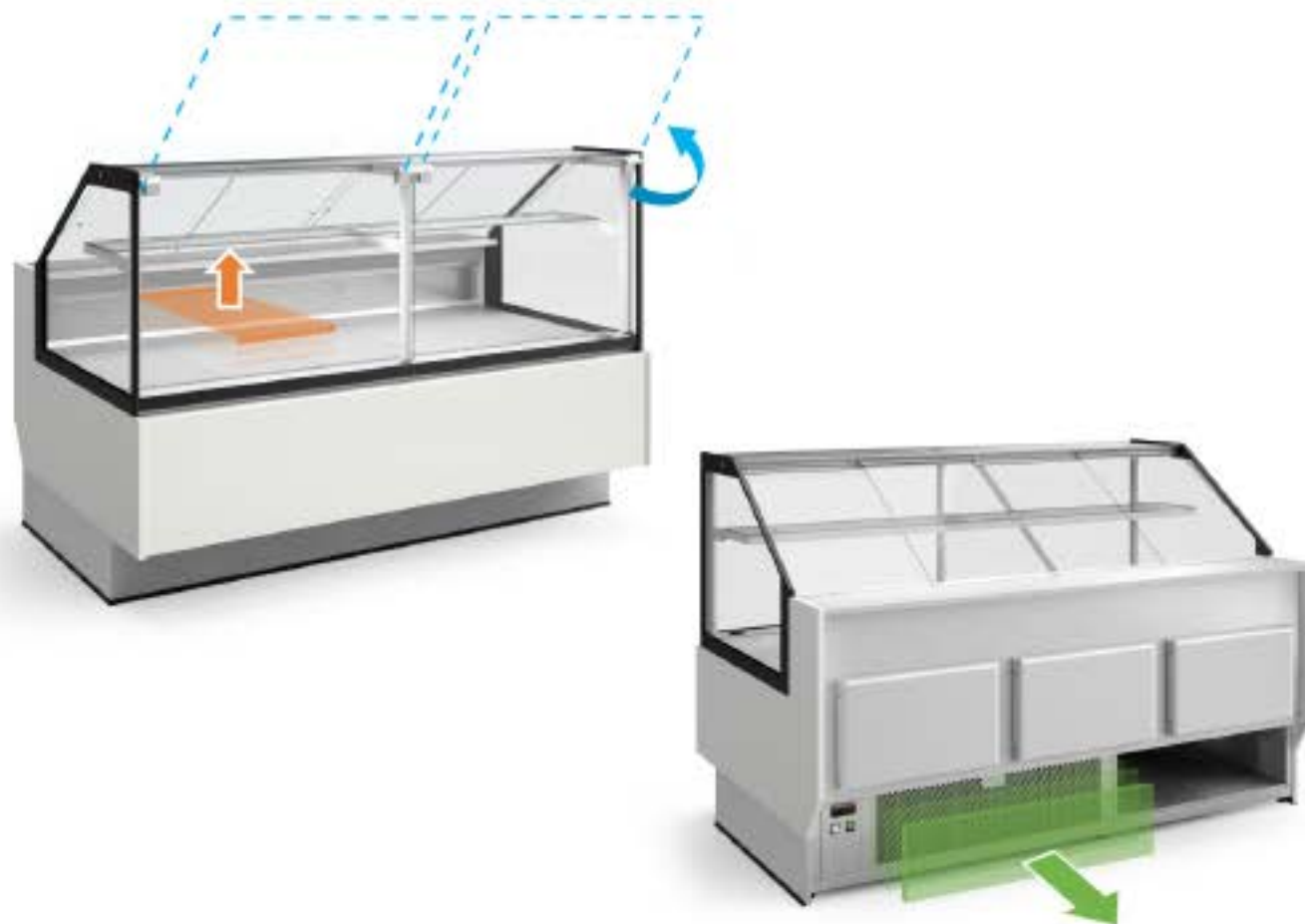

## PRESTIGE 2

### ERGONOMICS AND SERVICE

Efficient and ergonomic worktop.

Easy access to the display area  
and the refrigerated understorage

*Options:*

*Intermediate shelf*

*Gradins*

*Castor wheel kit*

*Acrylic product dividers*

*Bag-holder*

*Roller-shaped shelves*

*Knife-holder*

...

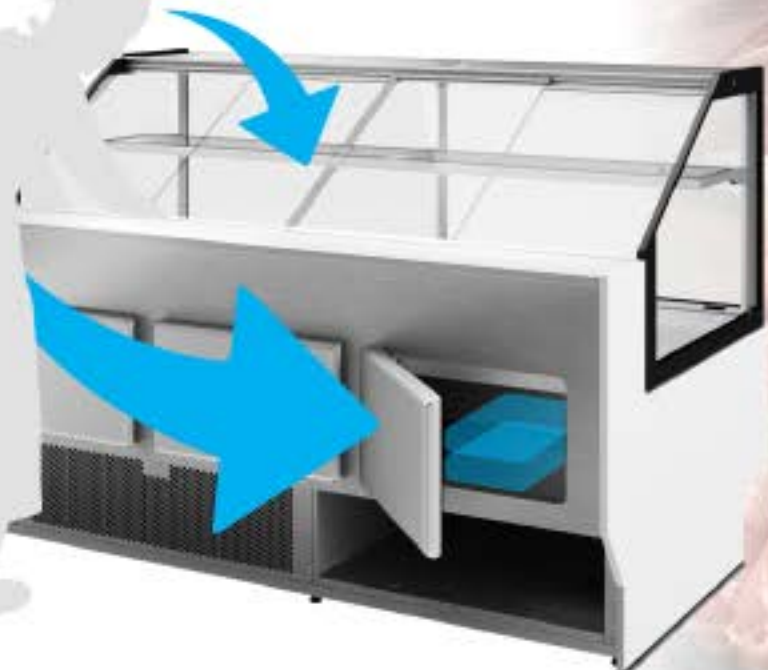



## PRESTIGE 2

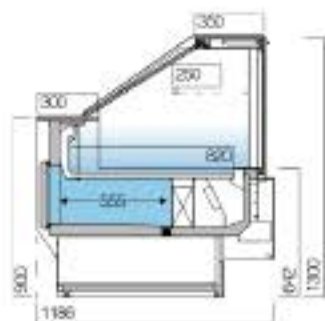

### REFRIGERATED DISPLAY CASES WITH UNDERSTORAGE M1

*dimensions without end side panels*

**built-in condenser unit R290**

937 | 1250 | 1562 | 1875 | 2500 mm

**remote condenser unit**

937 | 1250 | 1562 | 1875 | 2500 | 3125 | 3750 mm

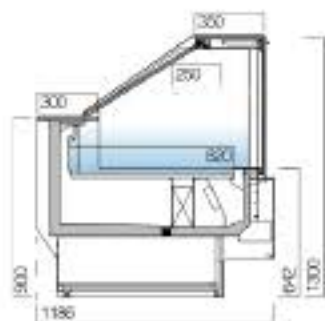

### REFRIGERATED DISPLAY CASES WITHOUT UNDERSTORAGE M1

*dimensions without end side panels*

**built-in condenser unit R290**

937 | 1250 | 1562 | 1875 | 2500 mm

**remote condenser unit**

937 | 1250 | 1562 | 1875 | 2500 | 3125 | 3750 mm

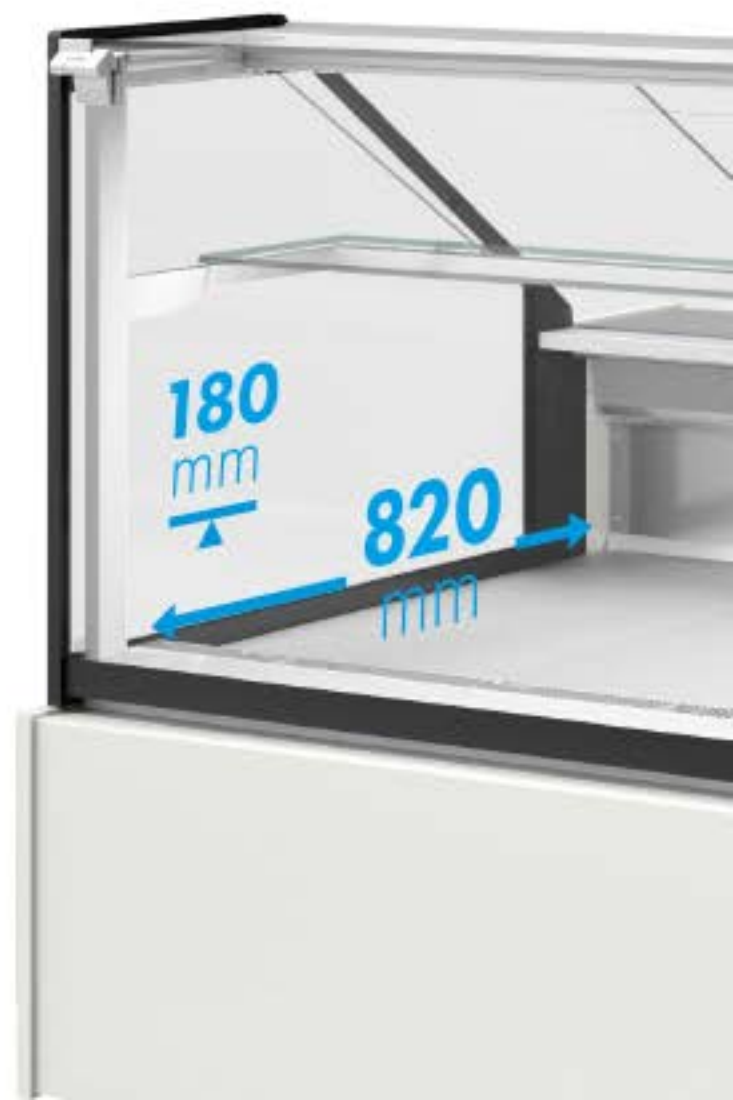

## PRESTIGE 2

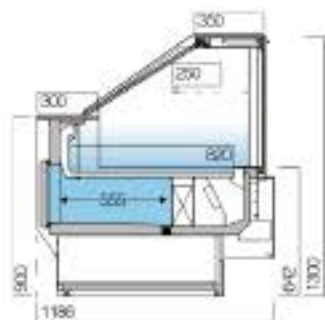

### REFRIGERATED DISPLAY CASES WITH UNDERSTORAGE M1

*dimensions without end side panels*

**built-in condenser unit R290**

937 | 1250 | 1562 | 1875 | 2500 mm

**remote condenser unit**

937 | 1250 | 1562 | 1875 | 2500 | 3125 | 3750 mm

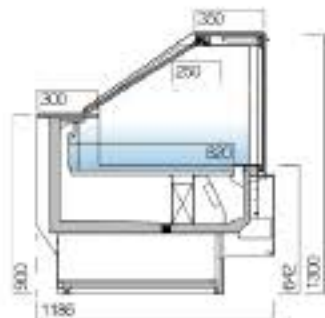

### REFRIGERATED DISPLAY CASES WITHOUT UNDERSTORAGE M1

*dimensions without end side panels*

**built-in condenser unit R290**

937 | 1250 | 1562 | 1875 | 2500 mm

**remote condenser unit**

937 | 1250 | 1562 | 1875 | 2500 | 3125 | 3750 mm

#### Note:

*New models soon...*

Cold plate

Saladette

Heated ventilated

Bain-marie

Hot plate



For:  
Bag-holder  
Roller Holders  
Knife Holders  
...

# PRESTIGE 2

## REFRIGERATED CORNERS M1

built-in condenser unit R290  
CIR45° | CIR90°

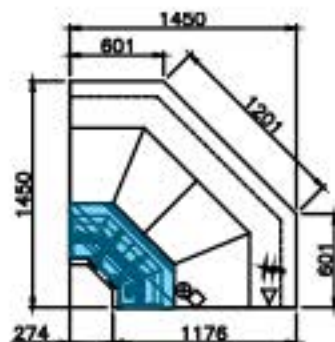
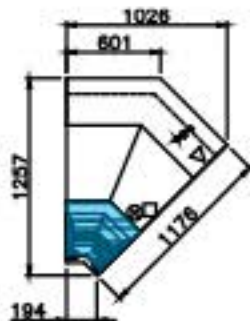

inner corners



## REFRIGERATED CORNERS M1

remote condenser unit  
CER45° | CER90° | CIR45° | CIR90°

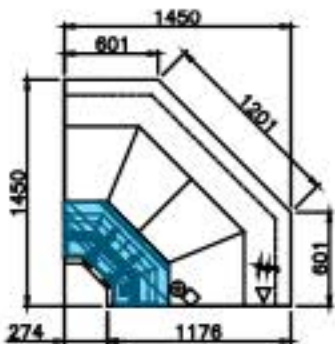
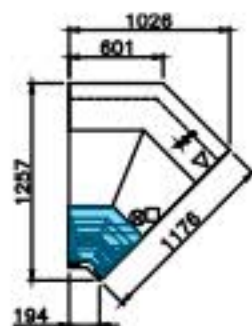
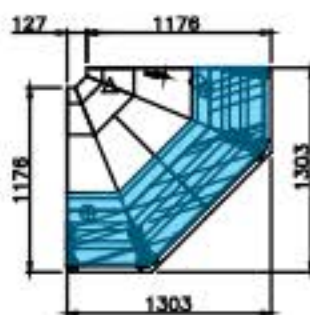
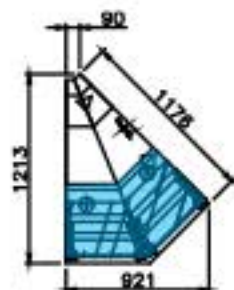

exterior corners





# PRESTIGE 2

## COUNTER 1N

dimensions without end side panels

### modules

625 | 937 | 1250 mm

### corners

CER45° | CER90° | CIR45° | CIR90°

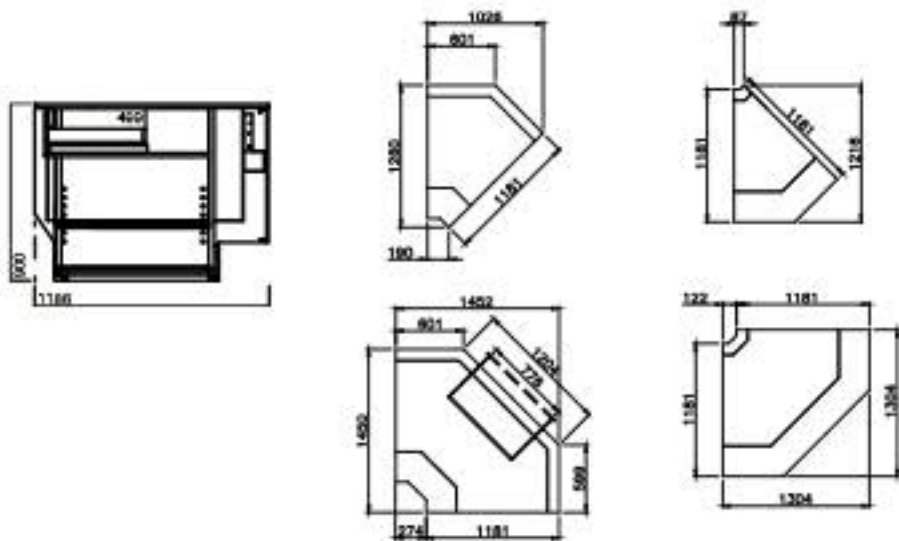

Counter 1N



## COUNTER PMR

dimensions without end side panels

### modules

625 | 937 | 1250 mm

### corners

CER45° | CER90° | CIR45° | CIR90°

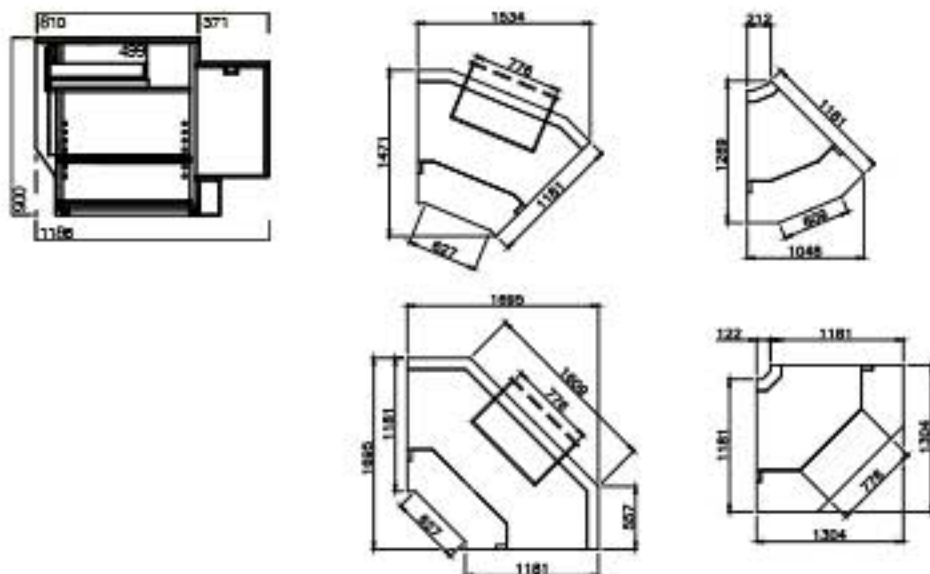

Counter PMR



## PRESTIGE 2

### EASY INSTALLATION

Perfect linears  
in a quick way

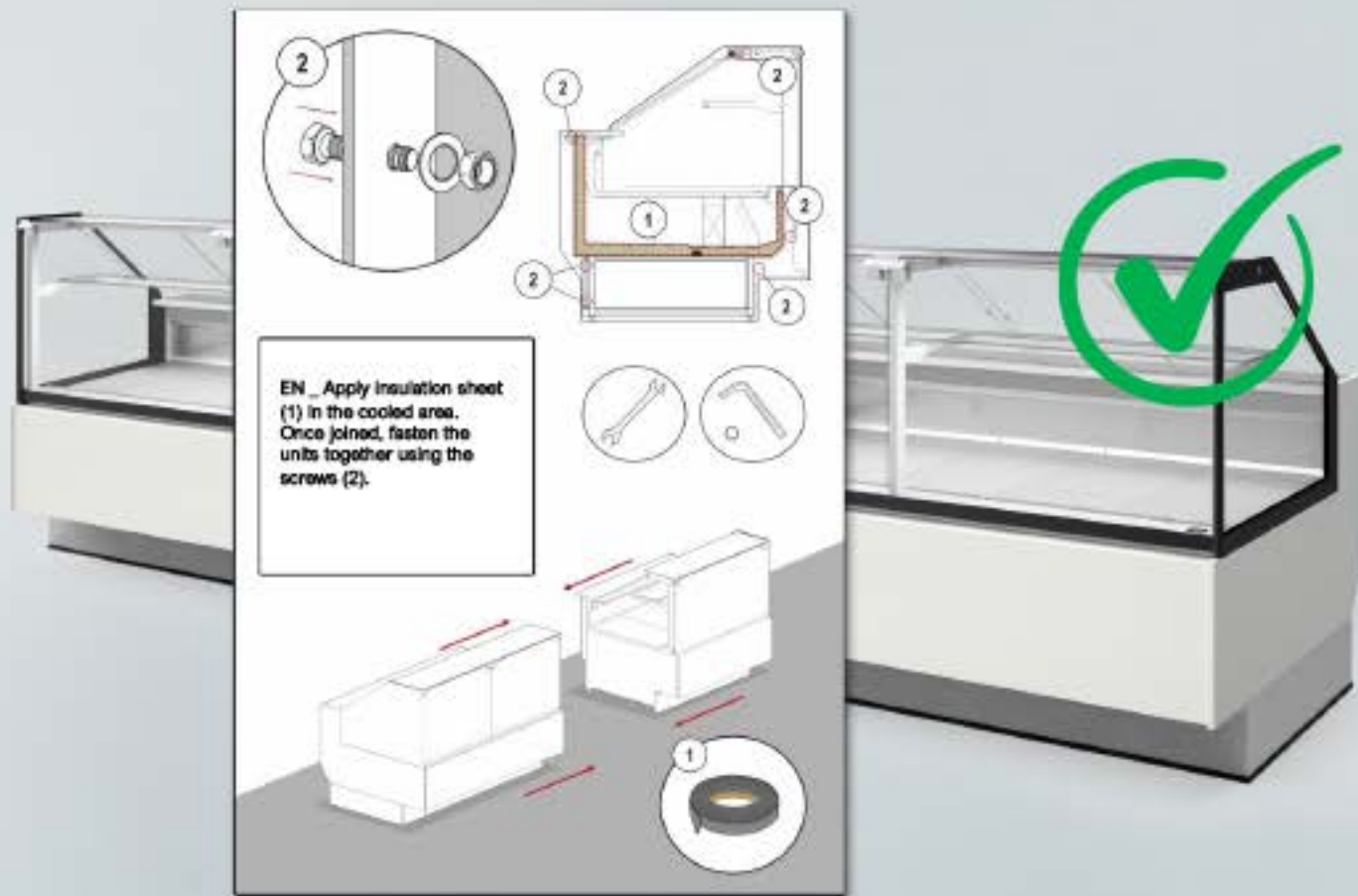

## PRESTIGE 2



### Take note! Advantages

- ✓ M1 Class – display cases and corners.
- ✓ Refrigerated undestorage available for built-in condenser unit models
- ✓ Passive anti-condensation system.
- ✓ Stainless steel interior and exterior vat.
- ✓ 2 frontal glass styles available, display cases and corners with easy opening.
- ✓ 2 stainless steel versions, the right price adjusted to the client's needs.
- ✓ Contemporary design, painted or laminated decoration, other options on request.



PRESTIGE 2



gti

DESIGNS

35 Trade Zone Court, Ronkonkoma, 11779 | 631-981-2100  
CustomerService@gtidesigns.com | www.gtidesigns.com