

# CC102



Fully automatic single cylinder table top machine, designed for the production and sale of fresh gelato and ice cream. The continuous churning process is done in front of customers, adding fresh liquid mix as the product is sold. A sophisticated, but easy to use, electronic controller guarantees the best texture and quality all the time.

It can produce Ice-Cream, Gelato, Sorbets, Frozen Yogurt, Granita, alcohol frozen drinks and more.

**Specifications :**

Model	Capacity	Production	Electric Power	Supply voltage	Average energy consumption	Dimensions	Weight
CC102 I	1-2 kg	6kg/hour	750W	220V-60Hz/1ph	350W/h	17"x 19" x 17.5"	135 lb

**OVERALL DIMENSIONS**

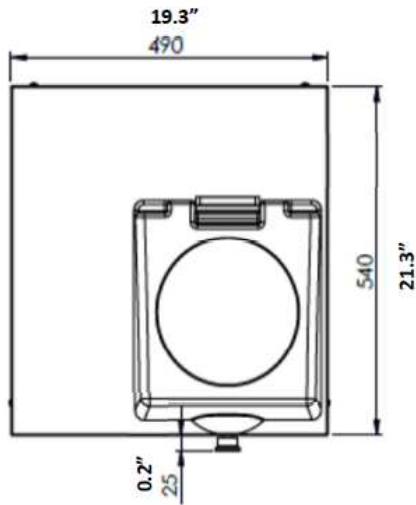
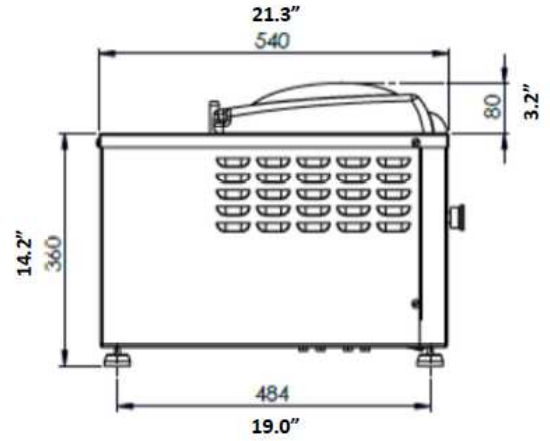
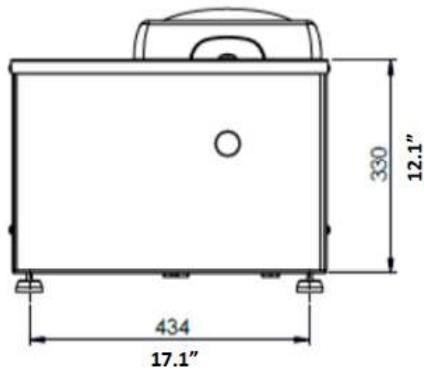

**Accessories :**

- Bezel with spatula

