

Maestro Display Drop-In

MAESTRO DROP-IN

The Maestro Drop-In is a range of drop-in counter tops and displays designed to fully showcase your products.

Extremely customizable and able to showcase a wide variety of food types.



DROP-IN

750 MAESTRO

- AMBIENT °
- Chilled 39.2°-60.8°
- Heated 140°
- Frozen -0.4° to -40°



750mm

This advanced Drop-In counter and display aims to showcase and preserve food at any temperature.

600 DOCK

- AMBIENT °
- Chilled 39.2°-60.8°
- Chilled 39.2°-60.8°
- Heated 140°



600mm

500 DROP-IN

- AMBIENT °
- Chilled 39.2°-60.8°
- Chilled 39.2°-60.8°
- Heated 140°



500mm

The 500mm depth Drop-In is a versatile and space efficient solution.

Combining style and functionality that can work in almost any space.



750 MAESTRO



- AMBIENT
°
- Chilled
39.2°-60.8°
- Heated
140°
- Frozen
-0.4° to -40°



A COMPACT BASE FOR THE PROFESSIONAL SHOWCASING.

Chilled temperatures for pastry cabinets, including a 29.5 inch deep display top, large enough to arrange a double row of trays. Ultimate visibility.

Also available for showcasing chocolates.



The Maestro basin is ideal for frozen products, able to hold a double row of professional ice cream tubs, pans, as well as frozen dessert products such as cakes, cups, and popsicles.



✱
Frozen
-0.4° to -40°



Chilled
39.2°-60.8°

Heated
140°

Frozen
-0.4° to -40°

The Maestro can be easily channeled, allowing for greater design creativity, as well as the ability to showcase several food types along side one another.



40°F





An Ultra-Modern Solution

750 MAESTRO

 **AMBIENT
TEMPERATURE**

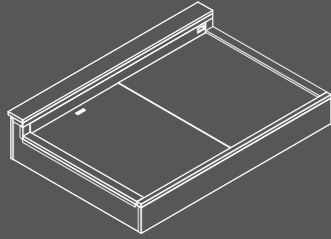

PRESERVING TECHNOLOGIES

- Ambient temperature
TECHNICAL FEATURES

Enbloc body with environment-friendly foamed polyurethane insulation, density 40/45 Kg/m³. Internal sheet iron structure with glossy covering. It is also available the 90° open module.

 **T+ 39.2° to 60.8°
CHILLED**
(ALSO AVAILABLE WITH HUMIDITY CONTROL)

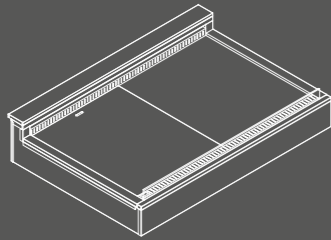

PRESERVING TECHNOLOGIES

- Positive temperature.
- Positive temperature with humidity control
- Positive temperature with cool/hot alternated functioning
TECHNICAL FEATURES

Monolithic body, insulated with ecologic foamed polyurethane, density 40/45 Kg/m³. External covering of the door made of galvanized sheet iron. For the positive temperature with cool/hot alternated functioning it is foresees a display top with heating elements. Warmed glass on the front side. It is also available the 90° open module.

 **T+ 140°
HEATED**
DRY WET WARMED

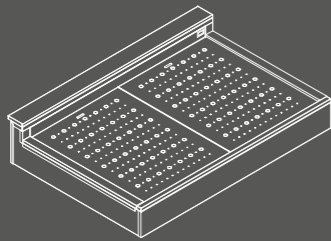

PRESERVING TECHNOLOGIES

- Dry Wet warmed
TECHNICAL FEATURES

Monolithic body, insulated with ecologic foamed polyurethane, density 40/45 Kg/m³. External covering of the door made of galvanized sheet iron. The basins are made of stainless steel (AISI304) with BA glossy finish and are prearranged for installing holed tops for the steam outlet. AISI 304 stainless steel basin with glossy finish prearranged for inserting holed tops for steam outlet.

 **-0.4° to -40°
FROZEN**

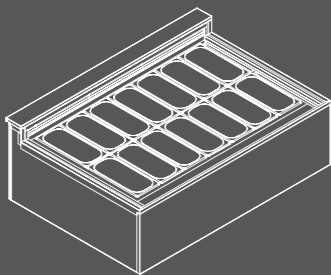

- Low temperature
TECHNICAL FEATURES

Enbloc body with environment-friendly foamed polyurethane insulation, density 40/45 Kg/m³. External stainless steel covering. Internal sheet iron structure with glossy covering. Front warmed glasses and side panels (on the right and on the left).

DIMENSIONS

SECTION

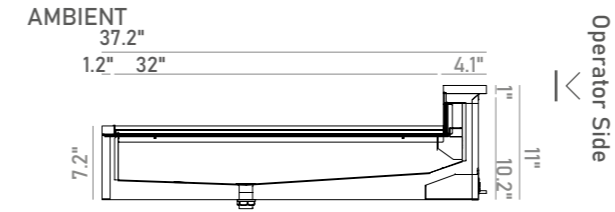

Operator Side

PLAN

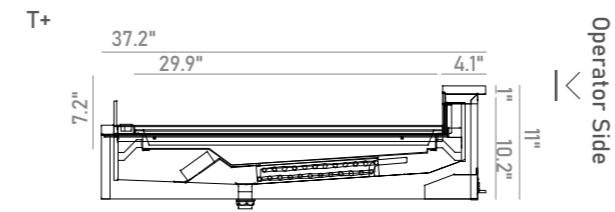
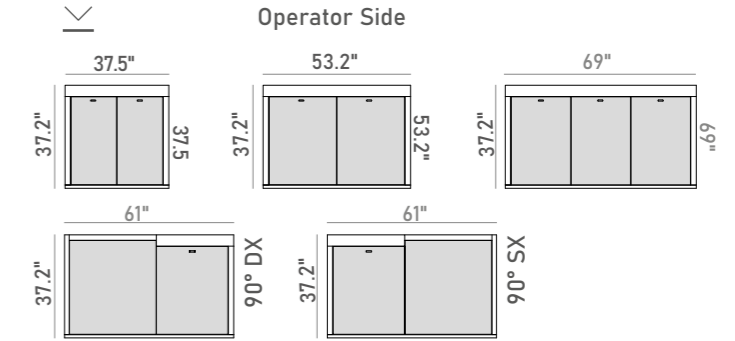

Operator Side

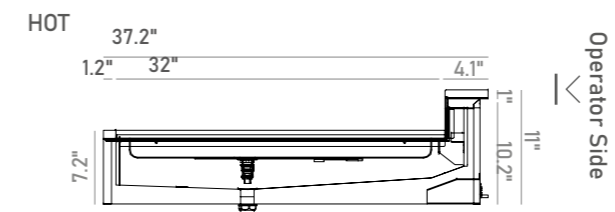
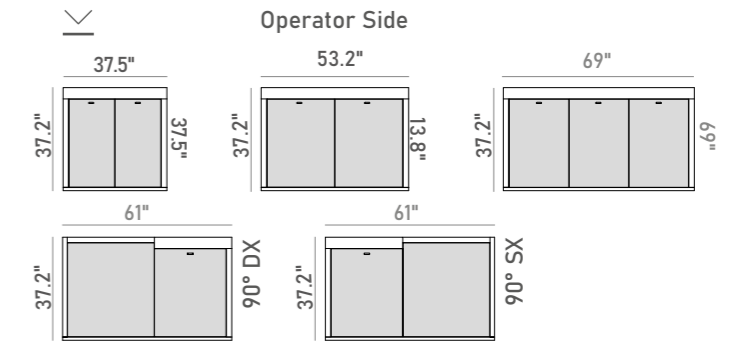

Operator Side

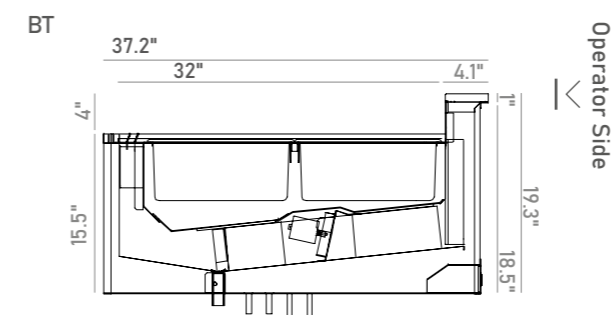
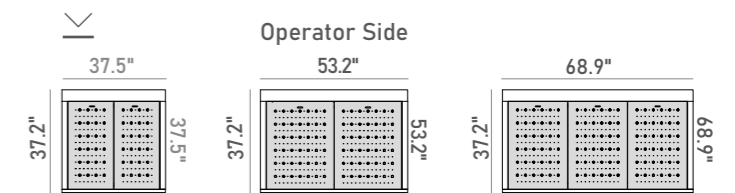

Operator Side

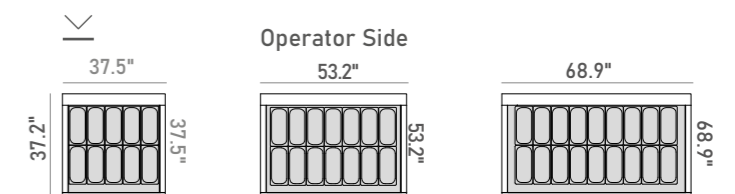

KEEP YOUR PRODUCTS VISIBLE

A contemporary, minimalist style.





35 Trade Zone Court, Ronkonkoma, NY 11779
631-981-2100
Customerservice@gtidesigns.com