

P Quadro

Case Features:

- Available for Gelato & Ice Cream, Pastry, Desserts
- Easy opening rear door
- LED light technology enhances presentation
- Fixed front glass or optional opening front glass
- Offered in various size configurations with multiple cases integrated together
- Available in coordinating 45° Angle Display Cases
- Classic European design – simple, stylish, elegant & functional



GELATO

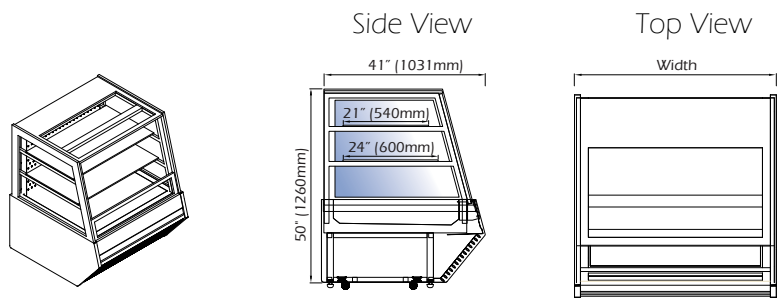
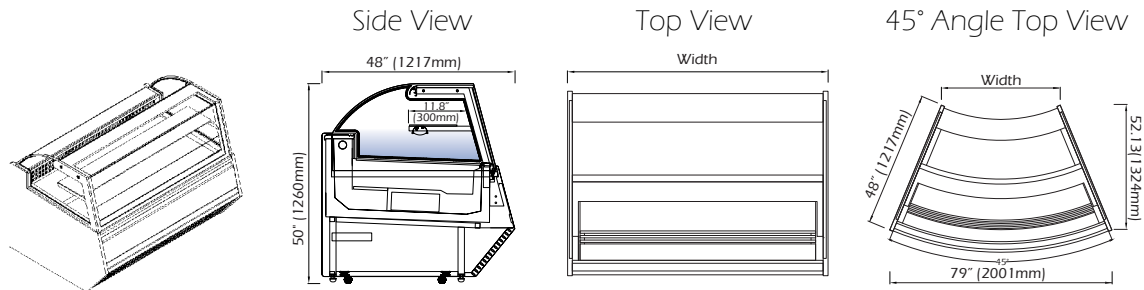
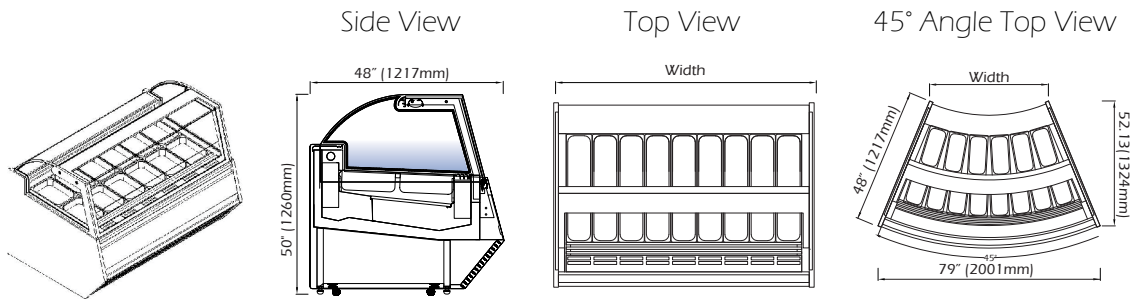

REFRIGERATED GRAB 'N' GO

DISPLAY CASES

Type	Model	Width	Depth	Height	Electrical Requirements
GELATO	PQ-12G	48" (1215mm)	48" (1217mm)	50" (1260mm)	220V/1Phase/60Hz/10 Amp
	PQ-16G	61" (1550mm)	48" (1217mm)	50" (1260mm)	220V/1Phase/60Hz/13 Amp
	PQ-18G	68" (1720mm)	48" (1217mm)	50" (1260mm)	220V/1Phase/60Hz/13 Amp
	PQ-24G	88.25" (2240mm)	48" (1217mm)	50" (1260mm)	220V/1Phase/60Hz/14 Amp
45° Angle	PQ-45G	79" (2001mm)	48" (1217mm)	50" (1260mm)	220V/1Phase/60Hz/10 Amp
	PQ-1215P	48" (1215mm)	48" (1217mm)	50" (1260mm)	220V/1Phase/60Hz/7 Amp
REFRIGERATED	PQ-1550P	61" (1550mm)	48" (1217mm)	50" (1260mm)	220V/1Phase/60Hz/8 Amp
	PQ-1720P	68" (1720mm)	48" (1217mm)	50" (1260mm)	220V/1Phase/60Hz/8 Amp
	PQ-2240P	88.25" (2240mm)	48" (1217mm)	50" (1260mm)	220V/1Phase/60Hz/9 Amp
	PQ-45P	79" (2001mm)	48" (1217mm)	50" (1260mm)	220V/1Phase/60Hz/5 Amp
Grab 'n' Go	PQ-1215PG	48" (1215mm)	46" (1031mm)	50" (1260mm)	220V/1Phase/60Hz/6 Amp
	PQ-1550PG	61" (1550mm)	46" (1031mm)	50" (1260mm)	220V/1Phase/60Hz/7 Amp
	PQ-1720PG	68" (1720mm)	46" (1031mm)	50" (1260mm)	220V/1Phase/60Hz/8 Amp

All technical data, pictures and drawings contained in this document are not binding on the manufacturer, nor can the manufacturer be held liable for any modification of the machine, in part or in whole.